

### DESCRIPTION

The Tractel® Group experience has propelled us to the forefront of providing safe, reliable and easy to use equipment for access to today's wind turbines.

The Trackbasket was designed to provide easy access to wind towers, providing easy maintenance to the blades and to the exterior of the tower. With three sets of padded bumper rollers, allows maintenance without damaging the exterior of the tower and blades. This modular platform gives unrestricted access to most of the towers exterior, making this a versatile and important part of your product repertoire.

### Trackbasket

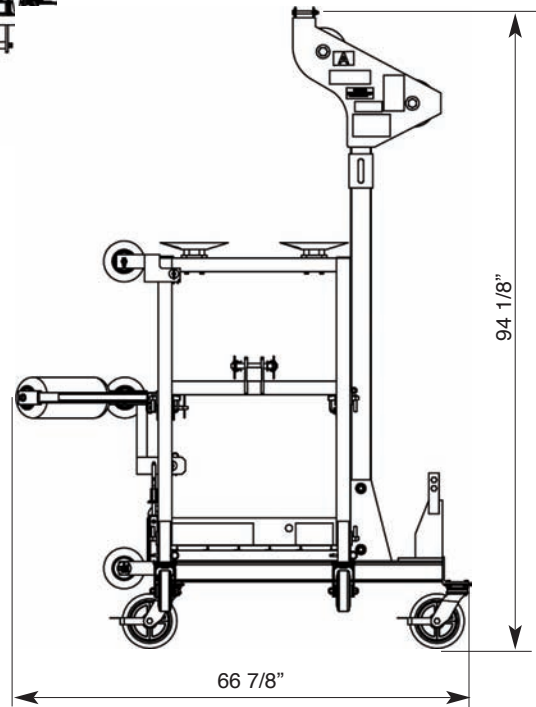
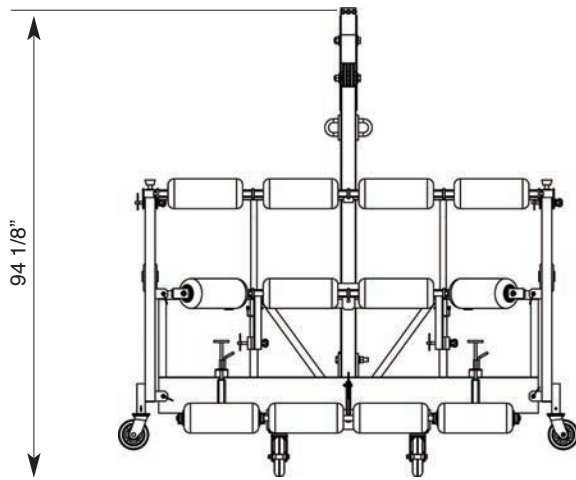
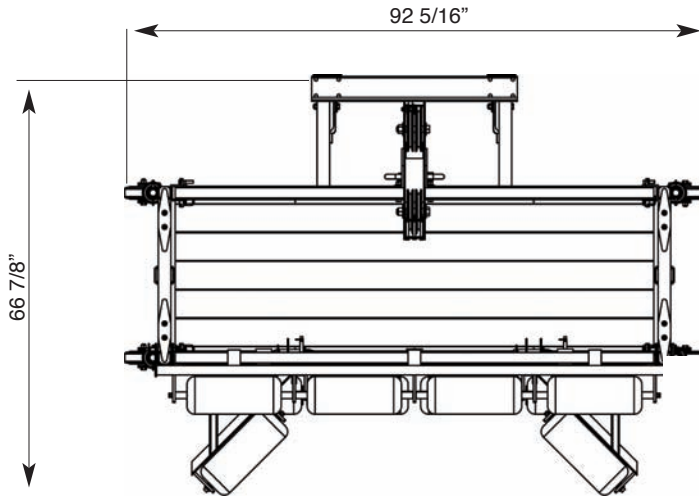
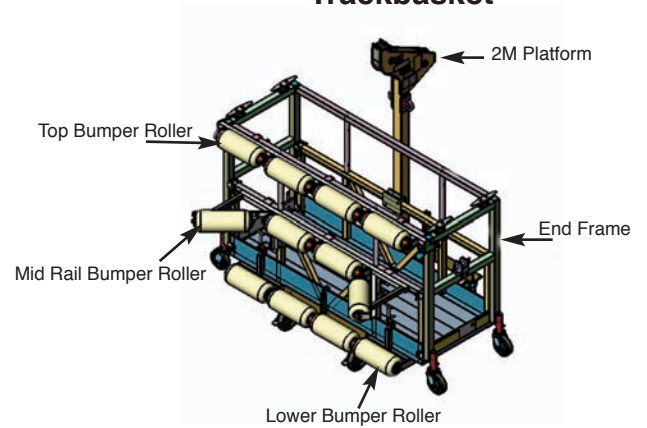

**Bumper Rollers**

**Description**

All bumper rollers located on the Trackbasket protect the exterior of the tower and the blades, while performing maintenance to the wind towers.

**2M Platform**

**Description**

The 2M Platforms are designed for working at heights in a safe manner.

**2M Platform**

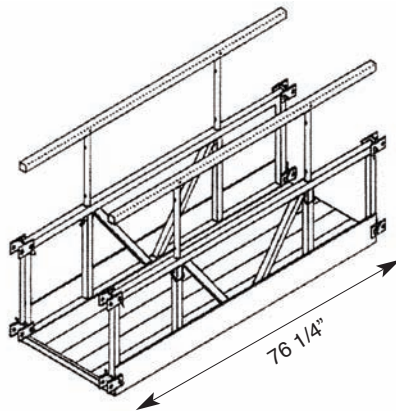

**Top Bumper**

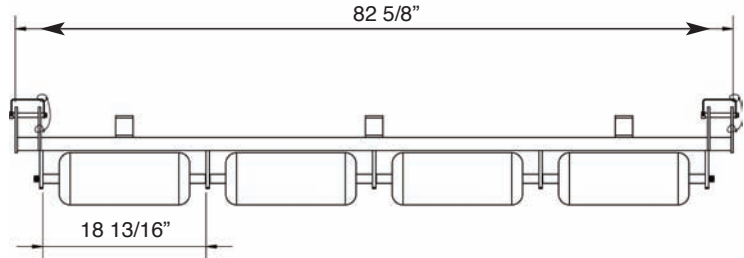

**Mid Rail Bumper Roller**

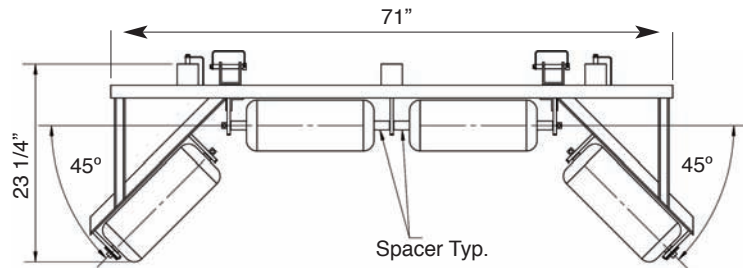

**Lower Bumper Roller**

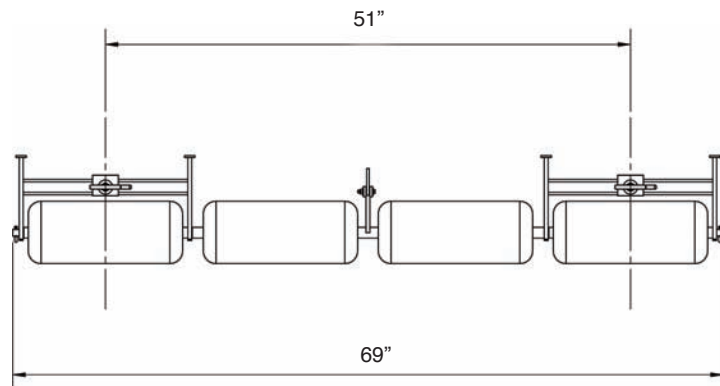

**End Frame**

**DESCRIPTION:**

The End Stirrups are made from heavy-duty aluminum material for a control and secure incline on wind towers. The castors on the Trackbasket are included to provide trailer loading and unloading, making the Trackbasket easy in mobility from site to site. The End Stirrups also include Heavy Duty Cleats that provide secure tie off points, for the front and back guide lines. This is used when raising the basket to blade level.

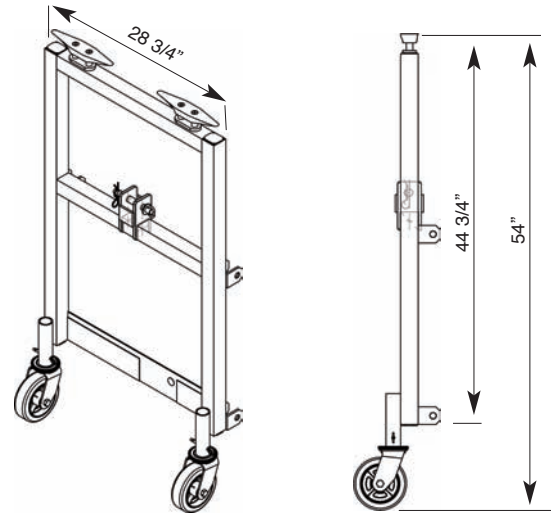

**Workcage Stirrup**

**DESCRIPTION:**

The Workcage Stirrup has been designed for use with the 6'6" (2m) Modular Suspended Platform (with the End Frames attached) as a workcage. The Workcage Stirrup uses only a single hoist, giving you the flexibility of a platform that is, stable and easy to operate.

The Workcage allows access for many applications including building inspection, wind tower maintenance and window cleaning, providing extra flexibility that a Bosun Chair just can't offer.

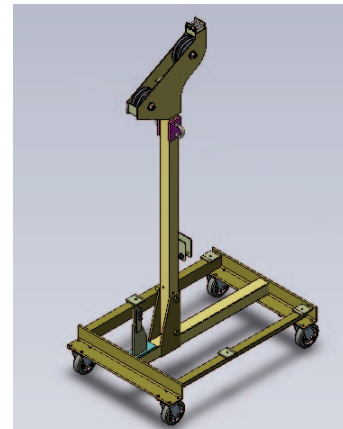
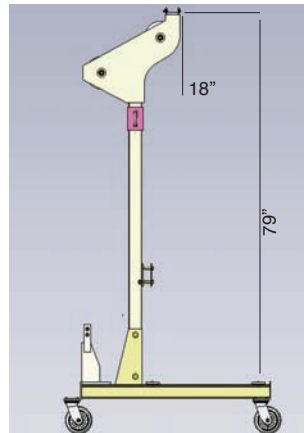
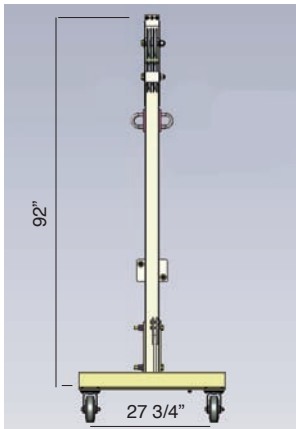

| MODEL #  | DESCRIPTION            | WEIGHT            |
|----------|------------------------|-------------------|
| PMR0080  | Top Bumper Roller      | 22 lbs. (10 kg)   |
| PMR0090  | Mid Rail Bumper Roller | 27 lbs. (12 kg)   |
| PMR0049  | Lower Bumper Roller    | 31 lbs. (14 kg)   |
| PMR0070  | End Frame              | 30 lbs. (14 kg)   |
| PMR0720D | Workcage Stirrup       | 233 lbs. (106 kg) |
| PMR1700D | 2M Platform            | 95 lbs. (43.1 kg) |

