

APPLICATIONS

Turning of any type of loads.

DESCRIPTION

The principle of PalTurn™ is to turn a load over in a space thanks to flat straps.

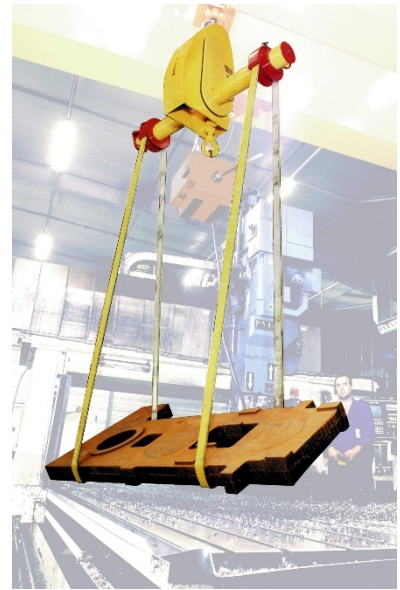
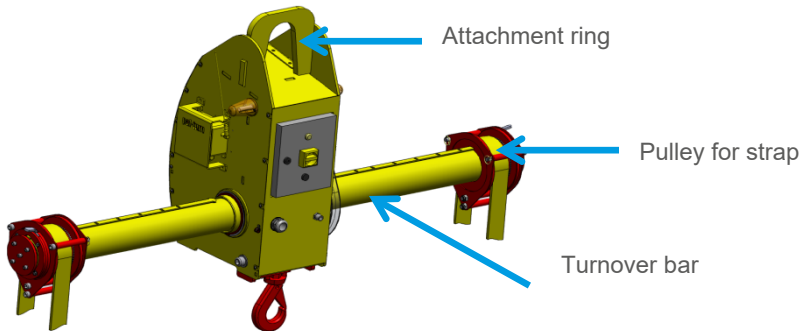

PalTurn™ is made up of a bar - rotated by a gear motor – driving the load via straps fitted onto encased drive pulleys. A control button box enables the functioning of the system.

The use of PalTurn™ does not require any anchoring point on the turned over load – the load is supported by the straps.

Each device can turn over different types of load, insofar as the capacity is adequate and the available straps have an adapted length.

FUNCTIONING

- Accrocher PalTurn™ sur votre moyen de levage.
- Installer les sangles dans les poulies.
- Adjustable model:
 - adjust the pulleys' position by lifting up the indexing lever.
 - Insure the locking of the pulley (indexing lever engaged in the indexing hole on driving key)
- Position the straps on the load. Take care that the straps are in the axle of the pulleys. Lock them in case of opening straps (see description page 2).
- Once the load is ready, lift it up.
- Check its horizontality.
- If required, lay down the load and adjust the position of the lifting means hook, in order to line it up with the COG of the load.
- Repeat the operation until the load is balanced and then turn on Pal Turn™ thanks to its remote control.

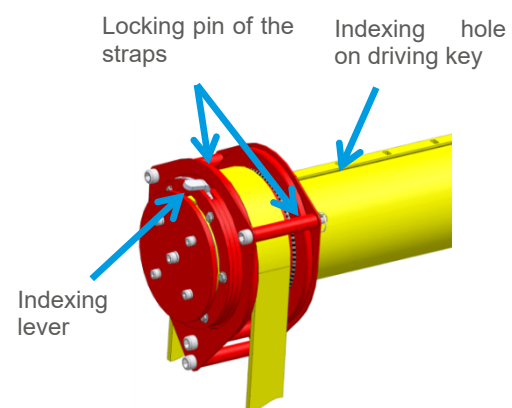
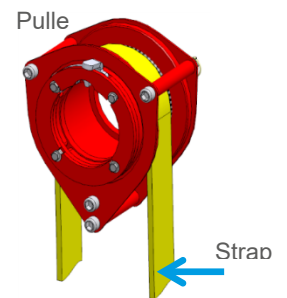

HANGING SYSTEM

Afin d'adapter PalTurn™ aux différentes installations, il existe plusieurs systèmes d'accrochage supérieur pour crochets simples ou doubles.

TURNING OVER PULLEYS AND ADJUSTMENT

So as to increase safety, the straps are placed under 2 assemblies of screws and braces, to maintain the straps in the groove of the sheave. Pulleys may be fixed or adjustable on the whole length of the tube. An ergonomic device enable their locking through indexing (in case of adjustable pulleys).

LOAD HOLD

PalTurn™ functions with flat textile straps.

The choice of the strap's length and type** and its coating* is made according to:

- The load: material, weight, perimeter,
- Set-up and use conditions,
- The respect of $\frac{1}{2}$ sling angle (α) included between 0 and 45° (maximum 60° if the height available under the hook does not allow to limit the $\frac{1}{2}$ sling angle to 45°).

The straps are tailor-made, depending on the imperatives of each use. The lifespan – in normal use and storage conditions – is very good.

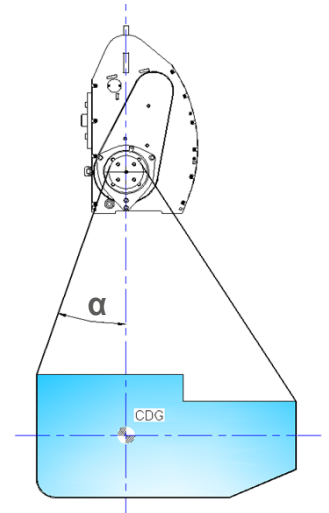

****impregnated straps***

regular loads with no sharp edges

Highly resistant to abrasion and with a high adherence coefficient, they are flexible and long lasting.

****coated straps***

restrictive loads with sharp edges

Highly resistant to abrasion and tearing ; their adherence coefficient is high and they are very long lasting.

** Different strap types:

- Endless straps: they can be used without any particular precaution.
- Opening straps: with a connection buckle (usually used when access to the ends of the load is difficult) must be particularly monitored during the use. The steel fittings of the buckle should not, under any circumstance, go inside the pulleys and the connection buckle, which is not covered with polyurethane, does never touch the sharp or delicate edges during the turnover.

ELECTRICAL CONTROL AND SUPPLY

PalTurn™ is equipped with a switch box for protecting the motor and the user (except 0.5 & 1 ton model).

Remote control with cable or cordless on request.

The standard cable button box is connected on the control box of the load turnover system through a "harting" type six-contacts connector. The end-user can easily ensure connection of the PalTurn™ control on the one of the lifting device (connection on site not provided by Tractel Solutions) using this available "harting" type connector.

The cable for power supply is separated and can be connected either on the floor or on the lifting device.

Electrical supply through three-phase network (3 phases + 1 earth connection) or batteries (model 2 t max.)

The turnover can be single- or double-speed.

Standard IP54 electrical protection index (protection against dust: no noxious deposit ; protection against water ejections from all directions)/other index on request.

HORIZONTALITY SIGNALLING SYSTEM¹

An imbalance system can be fitted to your Pal Turn™. It is designed to show the imbalanced position of the Pal Turn™ by a sound and/or light signal, i.e. to show that the Pal Turn™ has reached an inclination angle greater than 6° with respect to the horizontal plane. This system only represents a means of information to the user with regard to the approximate angular position of the Pal Turn™ however, it does not, under any circumstance, prevent the product from being used.

In case of imbalance being noticed, the load should be quickly lowered and held in a safe manner. The equilibrium of the load can be re established (perfect horizontal position during the lifting), before relifting and turning of the charge.

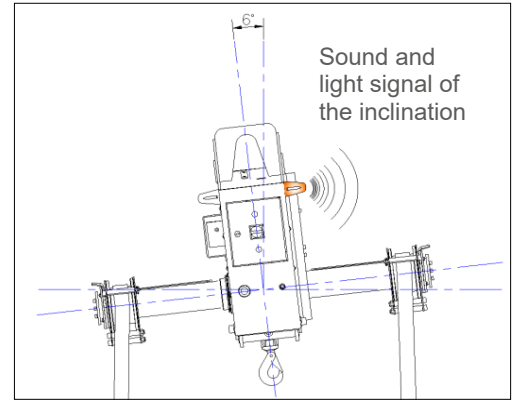

This optional equipment has 2 functions:

- Help the operator when balancing the load,
- Notify the operator in case the load be unbalanced during turning operations.

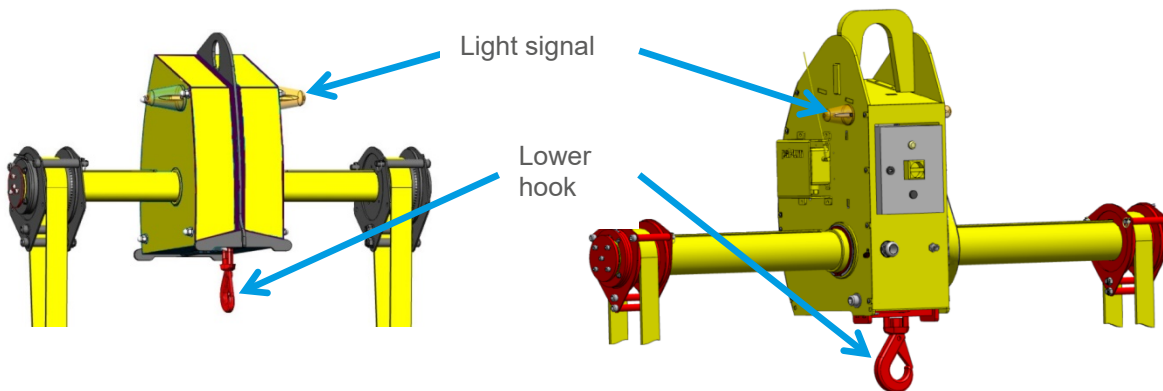

RETRACTABLE LOWER HOOK¹

This option allows load lifting without setting down Pal Turn™. It makes the installation of Pal Turn™ straps easier for some applications. For example : a permanent magnet lifter **magfor** (range available up to 5 tons) can be installed on this hook in case of iron steel loads.

The hook capacity is the same as the turner capacity.

During the lay down of the device, the lower attachment system is retractable inside pal-turn.

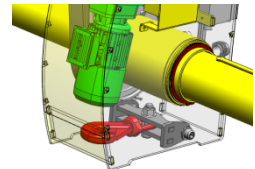

LIFTING POINTS¹

Loads can be lifted thanks to lifting points – fixed or adjustable – set up on the turner bar, without laying Pal Turn™ down. Accessories (slings, hooks...) hung to these points with shackles have to be removed for turning over.

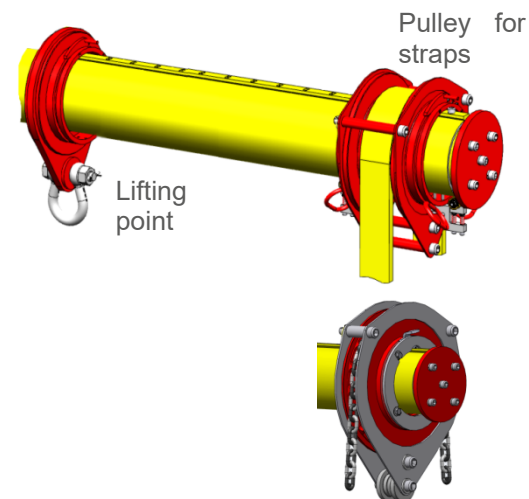

CHAIN PULLEY¹

Model with chains for high temperature loads (> 80°C) or for other use

¹ Not available for 0.5t PalTurn

HANDLING FRAMEWORK

The handling framework, on request, allow a secured moving of the device with a lifting truck.

The framework can also be equipped with wheels for a surface moving.

Caution: never turn the load over with the framework fixed under the device.

CONSIGNES PARTICULIERES

- The hook of the lifting means must stay upon the centre of gravity of the load (perfect horizontality under the turner during the lifting).
- Check the straps are correctly vertically positioned on the pulleys, in order to minimize the possible risk of load mismatch during the turning over.
- The section of the load directly below each strap must approximately have the same perimeter.
- In case of a simultaneous turnover with several loads, it is imperative to make them jointly liable.
- Check before the turnover that the load type and the straps choice are compatible (sharp edges, abrasion...).
- Check that the load characteristics can stand the stresses generated by the turn over (compressive stress on the straps, pressure on the load edges...).
- Check that the load is rigid enough not to deform itself in the straps – stiffen if necessary.
- Check the load temperature (max. temperature: 80°C – beyond contact Tractel Solutions).
- The load must have a minimal weight of 10% of the device WLL. Below this value, straps or pulleys may slip.
- When in continuous use, the rotation can cause the load to move horizontally.
- Always check that the pulley indexing is well-latched in the driving key hole (adjustable model).
- The straps can not be used if there are some oil or water on polyurethane.
- The users must particularly pay caution to the Pal Turn™ use. The condition of the straps must be regularly checked.
- Before any use, check that the capacity of the lifting device is adapted to the load turner capacity, including the weight of the device itself.
- Never exceed the working load limit WLL.

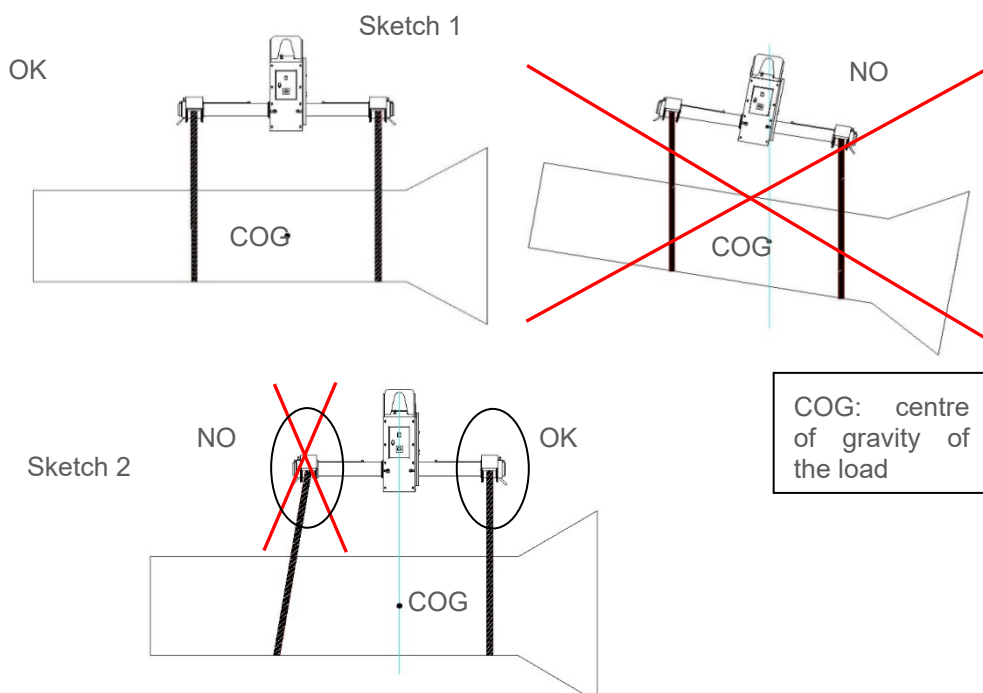
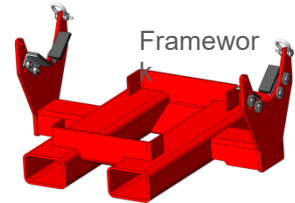
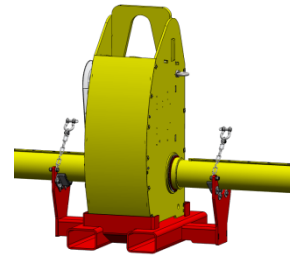

Special case: applications requiring the use of 2 load turners in a synchronized use

It is possible to use 2 synchronized load turners with the same control in the following cases:

- Very long loads,
- When 2 lifting means are used to obtain the adequate lifting capacity,

In such a case, each Pal Turn™ is equipped with 1 or 2 straps, depending of the use imperatives.

In case of 2 classic load turners with 2 straps, the devices can be used together or separately.

Mono-strap turner

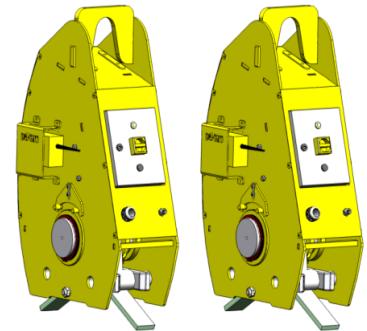

IMPORTANT INSTRUCTIONS

- Install each device on a hoisting means adapted to the load.
- During the connection of the load turners to the electrical installation, check that the rotation is in the same sense for each device.
- During the positioning, check that the devices are oriented so as to insure a rotation in the same direction.
- The devices must lifted at the same time so as to insure the load horizontality during the lifting – before, during and after the turnover – during the load setting down.
- During the positioning of the devices, check that the load is uniformly distributed on the 2 devices: the devices must be spaced equidistantly from the center of gravity COG axle of the load.
- If the below criterion cannot be respected during the application, the WLL of the devices must take into account the load offset of one of the devices.

2 single-strap turners

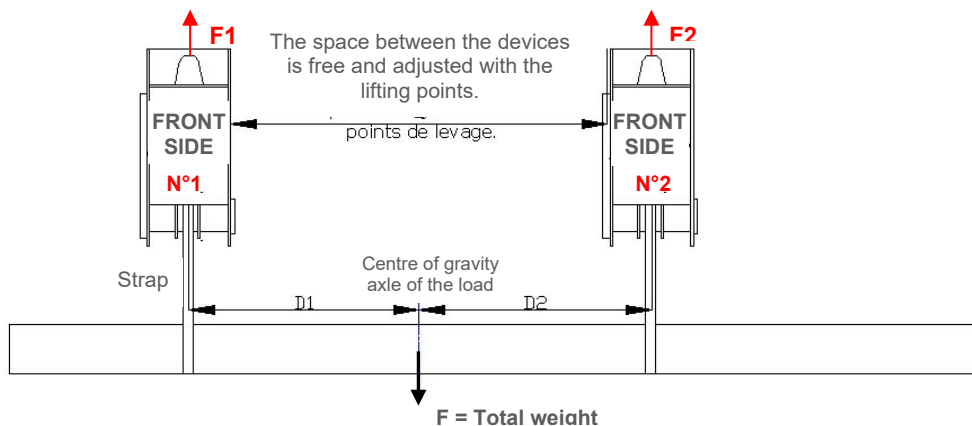

Important checks:
 $F_1 = D_2 * F / (D_1 + D_2) < \text{CMU Pal-Turn N°1}$
 $F_2 = D_1 * F / (D_1 + D_2) < \text{CMU Pal-Turn N°2}$

2 classic turners

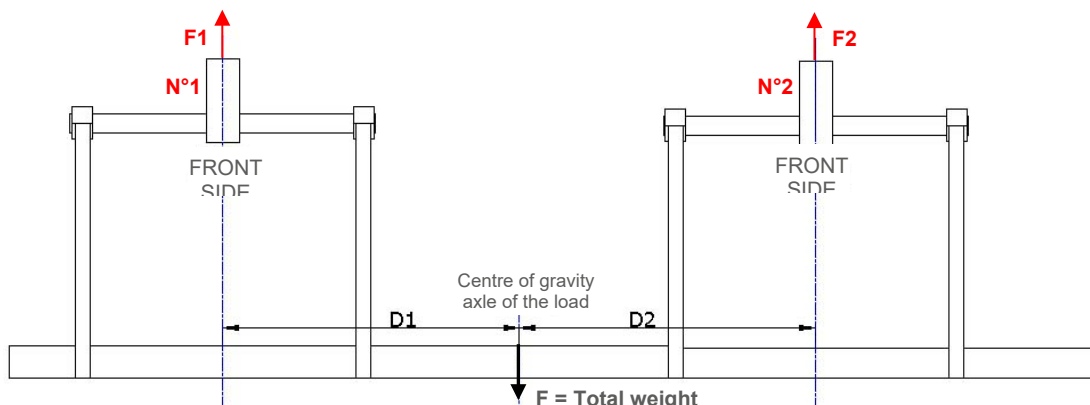

GENERAL CHARACTERISTICS

- Hot epoxy coating.
- Product conforms to the European regulation.

DIMENSIONAL CHARACTERISTICS

Except specific information, Pal Turn™ are designed in accordance with FEM 87 rules:

Use group = FEMA5

lifting speed = 30 m/min

A = maximum straps spacing. Adjusted dimensions on request

	WLL	Straps width	Mini spacing	C	Ø D	E	F	G	Total height H	Dead height Hp	I	Group code
	t		B									
Pal-turn™	0.5	30	460	1250	80	50	212	435	482	320	138	211968 / 211978
	1	60	500	A+360	132	100	265	532	680	390	172	
	2	60	600	A+360	132	100	370	590	1015	660	225	
	5	60	600	A+360	132	100	370	590	1015	660	225	
	10	120	1000	A+440	200	200	470	990	1600	865	530	
	20	120	1200	A+540	250	260	580	1040	1785	1010	530	
Mono-pulley	2x2	120	410	/	/	140	405	733	1160	780	255	Special
	2x5	120	410	/	/	140	405	733	1160	780	255	
	2x10	120	650	/	/	160	620	690	1675	1155	350	
	2x15	120	680	/	/	160	672	690	1695	1175	350	

Dimensions in mm

	WLL	Ring **				Weight	Weight by supplementary m***	Engine power kW	Group code
	t	J	K	L	M	* kg			
Pal-turn™	0.5	15	30	100	80	103	/	0.18	211968 / 211978
	1	15	30	100	80	250	30	0,25	
	2	25	40	210	175	360	30	0,55	
	5	25	40	210	175	375	58	0,75	
	10	30	70	200	200	1140		1,50	
	20	30	85	350	200	1720		3,00	
Mono-pulley	2x2	25	40	210	175	280	Ask us	0,55	Special
	2x5	25	40	210	175	280		0,75	
	2x10	30	50	215	200	710		1,50	
	2x15	30	50	215	200	750		3,00	

Dimensions in mm

* Indicative weight for a spacing of 2500 mm, except PalTurn 500kg

** Standard ring for single hook

*** Estimated weight pour a spacing or 2500 mm, except PalTurn 500kg

The specified standard characteristics can be modified further to the project's requirements.
Detailed specification sheets available on request.

