

Measure & Control





Dynafor™ Load Indicators

Page 123–134

Mechanical Dynasafe™

Page 135–135

Electronic Dynasafe™

Page 136–140

Dynarope Tension Meters







Page 141–142

Anchor test equipment

Page 143–143

Dynafor loadcells

a wide range

	Handifor	Dynascale	Dynafor Industrial	Dynafor Pro	Dynafor Expert
					
Accuracy	±0,5%	±0,5%	±0,3 %	±0,2 %	±0,1 %
Capacity	20 kg to 200 kg	1 t to 12,5 t	1 t to 20 t	1 t to 250 t	0,5 t to 10 t
Functions	Tare, Peak hold, Units change (kg, daN, lbs)	Tare, Peak hold, Units change (kg, daN, lbs)	Tare, Peak hold, Units change (kg, daN, lbs)	Tare, Peak hold, Units change (kg, t, US ton, daN, lbs), Settable alarms, Data saving, Multiple readings	
Display	Display integrated on the loadcell with 14 mm digits	Display integrated on the load cell with 30 mm digits	Display integrated on the load cell with 18 mm digits	Multiple display options: <ul style="list-style-type: none"> • Multiple reading of load cells on the HHD, wireless range up to 400 m • Free app compatible with Android and iOS devices  <ul style="list-style-type: none"> • AL63 giant remote display with 1 to 4 load cells, wireless range up to 200 m. 	
Battery life	Up to 100 h	Up to 50h	Up to 300 h	Up to 1 000 h	
IP rating	IP40	IP54	IP65	IP65 as standard, IP67 available as option	IP64 as standard, IP67 available as option
Lifting accessories	None	Compatible with bow shackles and hooks	Compatible with bow shackles	Compatible with bow shackles	Compatible with bow and clevis shackles
Applications	<ul style="list-style-type: none"> • Hand weighing 	<ul style="list-style-type: none"> • Overhead weighing • Safety and lifting applications • Quality controls • Logistics 	<ul style="list-style-type: none"> • Overhead weighing • Force measurement testing • Towing applications • Safety and lifting applications 	<ul style="list-style-type: none"> • Overhead weighing • Force measurement testing • Towing applications • Safety and lifting applications • Water bag load testing • Heavylift projects • R&D projects • Load balancing • Load monitoring on lifting equipment 	<ul style="list-style-type: none"> • Overhead weighing • Force measurement testing • Towing applications • Safety and lifting applications • R&D projects • Load balancing • Load monitoring on lifting equipment



Handifor



A convenient electronic load indicator including hooks for measuring small weights, quickly and easily.

- 5-digit LCD display, 14 mm height
- Safety factor minimum of 4
- 0.5% accuracy of measuring range
- Units: kg, daN, lbs
- IP40 protection rating

Model	W.L.L (kg)	Accuracy (kg)	Rsolution (kg)	Weight (kg)	Code
Handifor 20	20	±0.1	0.1	0.5	199919
Handifor 50	50	±0.25	0.2	0.5	199929
Handifor 100	100	±0.5	0.2	0.6	199939
Handifor 200	200	±1	0.5	0.9	199949

Delivery includes the Handifor, S-hook and carabiner hook, user manual and declaration of conformity. Supplied in sturdy cardboard packaging.



Dynascale

Weighing hook

Featuring an integrated display, the Dynascale series of weighing hooks provides great visibility, with an accuracy of 0.5%.

- Capacity range from 1t up to 12.5t
- 5-digit LCD display, 30mm height
- 0.5% accuracy of measuring range
- Automatic time off set at 20 min (removal in option)
- Multiple integrated functions : On, Tare, Peak Hold, Units change (kg, lbs, daN)
- IP54 protection rating
- QR code on side face leading to technical documentation and traceability at all times

Model	W.L.L (t)	Accuracy (kg)	Resolution (kg)	Weight (kg)	Model
Dynascale 1t	1	±3	1	3.5	299089
Dynascale 3.2t	3.2	±9.6	2	3.6	299099
Dynascale 6.5t	6.5	±18.9	5	6.3	299109
Dynascale 12.5t	12.5	±37.5	10	15.8	299119
Infrared remote control (incl. as standard)	-	-	-	-	299319

The delivery includes the Dynascale, an infrared remote control, 2 shackles, its user manual, its calibration report and its declaration of conformity. Supplied in a plastic case with protective foam padding. Weights above include shackles.



Eye hook

Model	Product Code
Eye hook 1t-3.2t	299289
Eye hook 6.5t	299299
Eye hook 12.5t	299309



Swivel hooks

Model	Product Code
Swivel hook 1t-3.2t	40977
Swivel hook 6.3t-6.5t	105567
Swivel hook 12.5t-15t	113227
Swivel hook 20t	105587



Dynafor Industrial



Featuring an integrated display, the Dynafor Industrial series of load indicators provides great value, with an accuracy of 0.3%.

- Capacity range from 1t up to 20t
- 5-digit LCD display, 18mm height
- 0.3% accuracy of measuring range
- Automatic time off set at 20 min (removal in option)
- Multiple integrated functions : On, Tare, Peak Hold, Units change (kg, lbs, daN)
- IP65 protection rating
- QR code on front face leading to technical documentation and traceability at all time

Model	W.L.L (t)	Accuracy (kg)	Resolution (kg)	Weight (kg)	Product Code
Dynafor Industrial 1T	1	±3	1	0.75	260889
Dynafor Industrial 3.2T	3.2	±9.6	2	0.93	260899
Dynafor Industrial 6.3T	6.3	±18.9	5	1.44	260909
Dynafor Industrial 12.5T	12.5	±37.5	10	3.22	260919
Dynafor Industrial 20T	20	±60	20	4.95	260929
Option - Time off removal	-	-	-	-	281097

The delivery includes the Dynafor Industrial, its user manual, its calibration report and its declaration of conformity. Supplied in a plastic case with protective foam padding.



Bow shackles

Model	Product Code
Bow shackle 0.5-3.2T	47916
Bow shackle 5T-6.5T	47926
Bow shackle 10T-12.5T	47936
Bow shackle 20T-25T	47946



Swivel hooks

Model	Product Code
Swivel hook 1t-3.2t	40977
Swivel hook 6.3t-6.5t	105567
Swivel hook 12.5t-15t	113227
Swivel hook 20t	105587

Dynafor Pro



The Dynafor Pro is the latest version of a versatile and robust wireless digital dynamometer, used in various weighing and force measurement applications.

- Capacity range from 1t up to 250t
- Wireless connection using Radio-Frequency 2.4Ghz with Tractel® Dynafor HHD, large displays AL63, DMU and software accessories, up to 400m
- Wireless connection using Bluetooth® with any smartphone equipped with our free app', up to 30m
- Both Bluetooth® and Radio-Frequency 2.4 GHz available simultaneously
- Various possibilities using several Pro and accessories
- 0.2% accuracy of measuring range
- IP 65 protection rating (IP 67 in option)
- QR Code apposed on product leading to technical and traceability documentation

Model	W.L.L (t)	Accuracy (kg)	Resolution (kg)	Weight (kg)	Product Code
Dynafor Pro 1T	1	±2	0,2	0.7	293369
Dynafor Pro 3,2T	3.2	±6,4	0,5	0.86	293379
Dynafor Pro 6,5T	6.5	±13	1	1.6	293389
Dynafor Pro 15T	15	±30	5	3.66	293399
Dynafor Pro 25T	25	±50	10	5.33	293409
Dynafor Pro 50T	50	±100	20	11.45	293419
Dynafor Pro 100T	100	±200	50	27.48	293429
Dynafor Pro 250T	250	±500	100	97.98	293439
Option - IP 67	-	-	-	-	281077
Option - ISO 376 calibration : 0.5T to 10T	-	-	-	-	109407
Option - ISO 376 calibration : 10T to 50T	-	-	-	-	109417

The delivery includes the Dynafor Pro, its user manual, its calibration report and its declaration of conformity. Supplied in a plastic case with protective foam padding

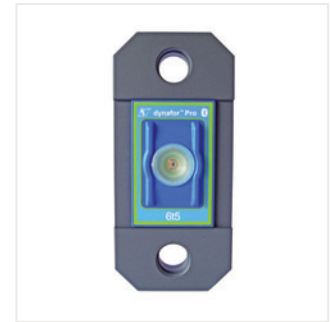

Exclusivity Dynafor HHD

Special offer when purchased with loadlink Dynafor



Intuitive, equipped with a colored-LED display, the Dynafor HHD is a complete and versatile handheld display, which offers endless functionalities.

Universal, the Dynafor HHD can be connected to our Dynafor Pro, Dynafor Expert and Dynafor Transmitter WL. Up to 4 equipments can be simultaneously connected.

Model	Product Code
Exclusivity - Dynafor HHD	293609

The delivery includes the Dynafor HHD, its user manual, its rugged plastic cover and its declaration of conformity. Supplied in sturdy cardboard packaging



Dynafor Pro

Lifting accessories



Bow shackles

Model	Product Code
Bow shackle 0.5-3.2T	47916
Bow shackle 5T-6.5T	47926
Bow shackle 10T-12.5T	47936
Bow shackle 15T	112427
Bow shackle 20T-25T	47946
Bow shackle 50T	47956
Bow shackle 100T	38166
Bow shackle 250T	93106



Swivel hooks

Model	Product Code
Swivel hook 1t-3.2t	40977
Swivel hook 6.3t-6.5t	105567
Swivel hook 12.5t-15t	113227
Swivel hook 25t	51207
Swivel hook 50t	51447



Order products on day 1, will be shipped no later than day 2.

Order products on day 1, will be shipped no later than day 6. Maximum quantities apply for this service.

Available on request. Please enquire about delivery times of these items.

Dynafor Pro

Display accessories

Dynafor HHD

Wireless display



The Dynafor HHD is a complete and versatile handheld display.

Universal, it can be connected to our Dynafor Pro, Dynafor Expert and Dynafor Transmitter WL.

- Wireless range up to 400m
- Single and multi-sensors (max. 4) reading with sum function
- Multiple display units (daN, kg, t, US Ton, lbs,kN)
- Tare & Peak hold functions
- Ergonomic interface
- Settable alarms with incorporated buzzer
- Manual data recording with up to 100 measures
- Autonomy up to 24h. Equipped with rechargeable battery. Charger included.
- Can be used in combination with large displays AL63 and DMU for modular solutions
- Can be used with Tractel App at the same time
- QR Code apposed on product for technical and traceability documentation



Model	Product Code
Dynafor HHD	293449

The delivery includes the Dynafor HHD, its user manual, its rugged plastic cover and its declaration of conformity..
Supplied in sturdy cardboard packaging

Dynafor AL63

High visibility displays



The Dynafor AL63 is designed to visualize the efforts or loads measured by one up to 4 sensors in a large display.

It can be wirelessly connected to our Dynafor Pro, Dynafor Expert, up to 200m range.

- Connection from 1 up to 4 sensors, with automatic sum function.
 - Visibility up to 45 m
 - Tare, peak hold, unit's selection with the TLC remote control.
 - Communication between Dynafor AL63 and sensors through RadioFrequency 2.4 GHz
 - Can be used with monitor Dynafor DMU
- Multiple configurations of monitors, sensors and displays are possible.



Model	Product Code
AL63 kit (incl. TLC remote control, connection unit)	294579
Power supply 110/230VAC -> 24 VDC	199046

The delivery includes the Dynafor AL63, its user manual, a remote control TLC, and its declaration of conformity.
Supplied in sturdy cardboard packaging

Dynafor Pro



Dynafor DMU

Display Monitoring Unit

The Dynafor DMU is a configurable safety device for managing 5 relays which are triggered in response to signals received from 1 or more electronic loadcells.

- Measure the rope tension or loads from 1 or more Dynafor Pro, Expert and Transmitter
- Manage 5 relays with adjustable thresholds and hysteresis
- Used for shutting down off equipments, powering on visual and audible alarms..
- Monitor the network
- Connect the unit to a AL63 LED display with a cable
- Connect the unit to a remote display HHD

Model	Product Code
Dynafor DMU - Display Monitoring Unit	293479
Power supply 110/230VAC -> 24 VDC	199046

The delivery includes the Dynafor DMU, its user manual, its declaration of conformity.
Supplied in sturdy cardboard packaging



Dynasoft - software for Dynafor

Connect your Dynafor load cells to your PC for additional functionality

The Dynasoft suite is composed of several modules:

- **Dynasoft Download** allows the transfer of measurements stored in our Dynafor HHD to the PC
- **Dynasoft Threshold Management** allows to transfer the alarm data saved in our Dynafor HHD to the PC
- **Dynasoft Monitoring** to perform real-time monitoring, recording and processing. The software needs to be used conjointly with our Dynafor HHD, and one to 16 Dynafor loadcells. Two packages are available. The basic and premium licenses are valid for an initial period of 1 year, which can be extended on expiration.

Model	Product Code
Dynasoft Basic (incl. Download & Threshold management) - First year	293509
Dynasoft Basic - renewal 1 year	287717
Dynasoft Premium (incl. Monitoring, Download & Threshold Management) - First year	294479
Dynasoft Premium - Renewal 1 year	287707

Softwares are delivered informatically, with an activation code.
Software activation requires Internet connection.

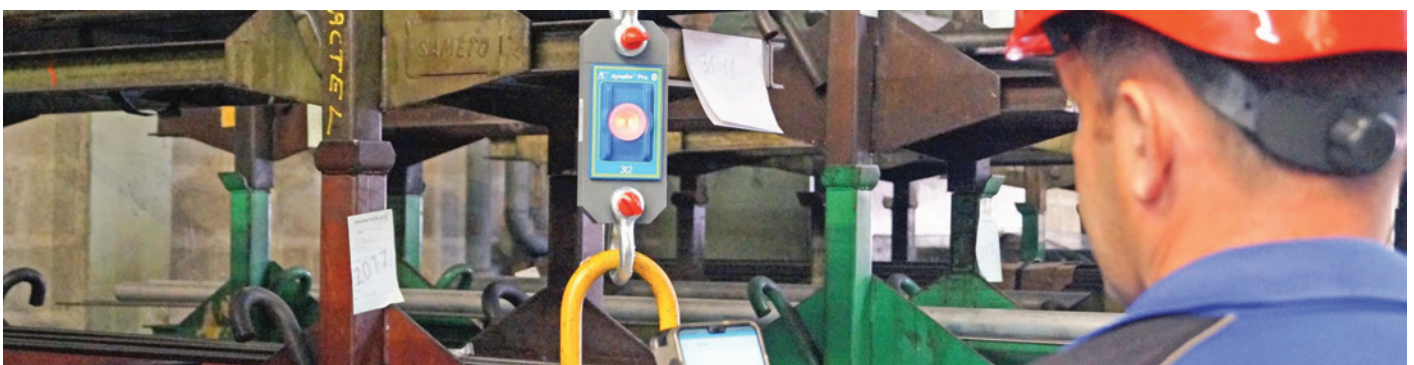

Dynafor Expert



The Dynafor Expert specific mechanical design allows it to be extremely precise.

- Capacity range from 0.5t up to 10t
- Wireless connection using Radio-Frequency 2.4Ghz with Tractel® Dynafor HHD, large displays AL63, DMU and software accessories, up to 400m
- Wireless connection using Bluetooth® with any smartphone equipped with our free app', up to 30m
- Both Bluetooth® and Radio-Frequency 2.4 GHz available simultaneously
- Various possibilities using several Expert and accessories
- 0.1% accuracy of measuring range
- IP 64 protection rating (IP 67 in option)
- Unique loadcell compatible with clevis hooks and shackles
- QR Code apposed on product leading to technical and traceability documentation



Model	WLL (t)	Accuracy (kg)	Resolution (kg)	Weight (kg)	Product Code
Dynafor Expert 0.5T	0.5	±0.5	0.1	2.3	293299
Dynafor Expert 1T	1	±1	0.2	2.3	293309
Dynafor Expert 2T	2	±2	0.5	2.3	293319
Dynafor Expert 3.2T	3.2	±3.2	0.5	2.3	293329
Dynafor Expert 5T	5	±5	1	3.35	293339
Dynafore Expert 6.3T	6.3	±6.3	1	3.35	293349
Dynafor Expert 10T	10	±10	2	6.45	293359
Option - IP 67	-	-	-	-	281067
Option - ISO 376 calibration : 0.5T to 10T	-	-	-	-	109407

The delivery includes the Dynafor Expert, its user manual, its calibration report and its declaration of conformity. Supplied in a plastic case with protective foam padding

Exclusivity Dynafor HHD

Special offer when purchased with loadlink Dynafor

Intuitive, equipped with a colored-LED display, the Dynafor HHD is a complete and versatile handheld display, which offers endless functionalities.

Universal, the Dynafor HHD can be connected to our Dynafor Pro, Dynafor Expert and Dynafor Transmitter WL. Up to 4 equipments can be simultaneously connected.

Model	Product Code
Exclusivity - Dynafor HHD	293609



Order products on day 1, will be shipped no later than day 2,

Order products on day 1, will be shipped no later than day 6. Maximum quantities apply for this service.

Available on request. Please enquire about delivery times of these items.

Dynafor Expert

Lifting Accessories



Bow shackles

Model	Product Code
Bow shackle 0.5-3.2T	47916
Bow shackle 5T-6.5T	47926
Bow shackle 10T-12.5T	47936



Clevis shackles

Model	Product Code
Clevis shackle 0.5T-3.2T	111407
Clevis shackle 5T-6.3T	111417
Clevis shackle 10T	112207



Clevis Hooks

Model	Product Code
Clevis hook 0.5T-3.2T	111437
Clevis hook 5T-6.3T	111447
Clevis hook 10T	112217

Dynafor Expert

Dynafor HHD

Wireless display



The Dynafor HHD is a complete and versatile handheld display.

Universal, it can be connected to our Dynafor Pro, Dynafor Expert and Dynafor Transmitter WL.

- Wireless range up to 400m
- Single and multi-sensors (max. 4) reading with sum function
- Multiple display units (daN, kg, t, US Ton, lbs,kN)
- Tare & Peak hold functions
- Ergonomic interface
- Settable alarms with incorporated buzzer
- Manual data recording with up to 100 measures
- Autonomy up to 24h. Equipped with rechargeable battery. Charger included.
- Can be used in combination with large displays AL63 and DMU for modular solutions
- Can be used with Tractel App at the same time
- QR Code apposed on product for technical and traceability documentation



Model	Product Code
Dynafor HHD	293449

The delivery includes the Dynafor HHD, its user manual, its rugged plastic cover and its declaration of conformity..
Supplied in sturdy cardboard packaging

Dynafor AL63

High visibility displays



The Dynafor AL63 is designed to visualize the efforts or loads measured by one up to 4 sensors in a large display.

It can be wirelessly connected to our Dynafor Pro, Dynafor Expert, up to 200m range.

- Connection from 1 up to 4 sensors, with automatic sum function.
 - Visibility up to 45 m
 - Tare, peak hold, unit's selection with the TLC remote control.
 - Communication between Dynafor AL63 and sensors through RadioFrequency 2.4 GHz
 - Can be used with monitor Dynafor DMU
- Multiple configurations of monitors, sensors and displays are possible.



Model	Product Code
AL63 kit (incl. TLC remote control, connection unit)	294579
Power supply 110/230VAC -> 24 VDC	199046

The delivery includes the Dynafor AL63, its user manual, a remote control TLC, and its declaration of conformity.
Supplied in sturdy cardboard packaging

Dynafor Expert



Dynafor DMU

Display Monitoring Unit

The Dynafor DMU is a configurable safety device for managing 5 relays which are triggered in response to signals received from 1 or more electronic loadcells.

- Measure the rope tension or loads from 1 or more Dynafor Pro, Expert and Transmitter
- Manage 5 relays with adjustable thresholds and hysteresis
- Used for shutting down off equipments, powering on visual and audible alarms..
- Monitor the network
- Connect the unit to a AL63 LED display with a cable
- Connect the unit to a remote display HHD

Model	Product Code
Dynafor DMU - Display Monitoring Unit	293479
Power supply 110/230VAC -> 24 VDC	199046

The delivery includes the Dynafor DMU, its user manual, its declaration of conformity. Supplied in sturdy cardboard packaging



Dynasoft - software for Dynafor

Connect your Dynafor load cells to your PC for additional functionality

The Dynasoft suite is composed of several modules:

- **Dynasoft Download** allows the transfer of measurements stored in our Dynafor HHD to the PC
- **Dynasoft Threshold Management** allows to transfer the alarm data saved in our Dynafor HHD to the PC
- **Dynasoft Monitoring** to perform real-time monitoring, recording and processing. The software needs to be used conjointly with our Dynafor HHD, and one to 16 Dynafor loadcells.

Two packages are available. The basic and premium licenses are valid for an initial period of 1 year, which can be extended on expiration.

Model	Product Code
Dynasoft Basic (incl. Download & Threshold management) - First year	293509
Dynasoft Basic - renewal 1 year	287717
Dynasoft Premium (incl. Monitoring, Download & Threshold Management) - First year	294479
Dynasoft Premium - Renewal 1 year	287707

Softwares are delivered informatically, with an activation code. Software activation requires Internet connection.



Mechanical Dynasafe

Quick and reliable load limiters

Dynasafe Mecha

Wire rope load limiter

The Dynasafe Mecha is a mechanical load limiter to be installed on a steel wire rope.

- 2 independant thresholds (max. 4A / 230 VAC)
- Can be used for overload protection, wire rope slack detection and others
- Easy to mount
- Repeatability of 1%
- Cable gland output - Lenght 2m
- QR Code apposed on product for technical and traceability documentation
- Factory setting available in option



Model	W.L.L (kg)	Rope Diameter (mm)	Product Code
Dynasafe Mecha 3.2	3200	5-16	293599
Dynasafe Mecha 7	7000	17-26	198959
Dynasafe Mecha 12	12000	27-36	38668
Option Mecha 3.2 - Extra cable lenght	-	-	282847
Option Mecha 7 - Extra cable lenght	-	-	288907

The delivery includes the Dynasafe Mecha, its user manual, its declaration of conformity. Supplied in sturdy cardboard packaging

Dynasafe HF 05

Dead-end load limiter

The Dynasafe HF05 is a mechanical load limiter to be installed on a fixed point (dead-end or specific mechanical design)

- Capacity up to 8 t
- 2 independant thresholds (max. 4A / 230 VAC)
- Can be used for overload protection and others
- Cable gland output - Lenght 2m
- Factory setting available in option



Model	W.L.L (kg)	Product Code
HF05/1/A2/AL	500	207298
HF05/2/A2/AL	1 250	207308
HF05/3/A2/AL	2 000	207318
HF05/4/A2/AL	3 200	207328
HF05/5/A2/AL	5 000	207338
HF05/6/A2/AL	8 000	207348

The delivery includes the Dynasafe HF05, its user manual, its declaration of conformity. Supplied in sturdy cardboard packaging

Dynasafe Mecha and HF05 setting

Price is for one threshold setting. For Mecha, setting is done on wire ropes of structure 6X36 or 7X19, at the nearest diameter available at factory.

Electronic Dynasafe

Applications

When a mechanical solution is not enough, and you want to :

- Display a load
- Integrate a sensor signal to your PLC (Programmable Logic Controller)
- Do real-time monitoring and relay management
- Manage several sensors individually and together

From the sensor definition, to the accessories option, Tractel supports you in defining an electronic solution that meets your requirements.

How to define a Dynasafe solution

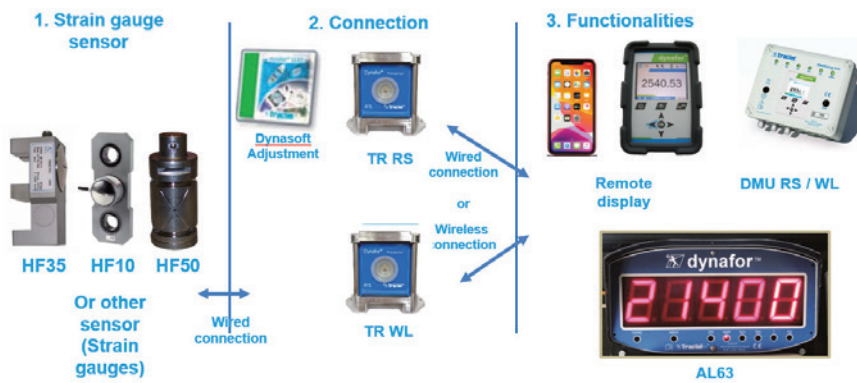

1. Select or design a strain gauge sensor that fits perfectly in your application. Tractel offers standards sensors as well as specific sensors.
2. Define what type of connection do you need :
 - Wired connection through our Dynafor™ Transmitter RS
 - Wireless connection through our Dynafor™ Transmitter WL
 - Standard wired conditioner for analog output (4-20 mA, 0-10V)
3. Select the correct Tractel accessories to fulfill your needs

A fully modular system

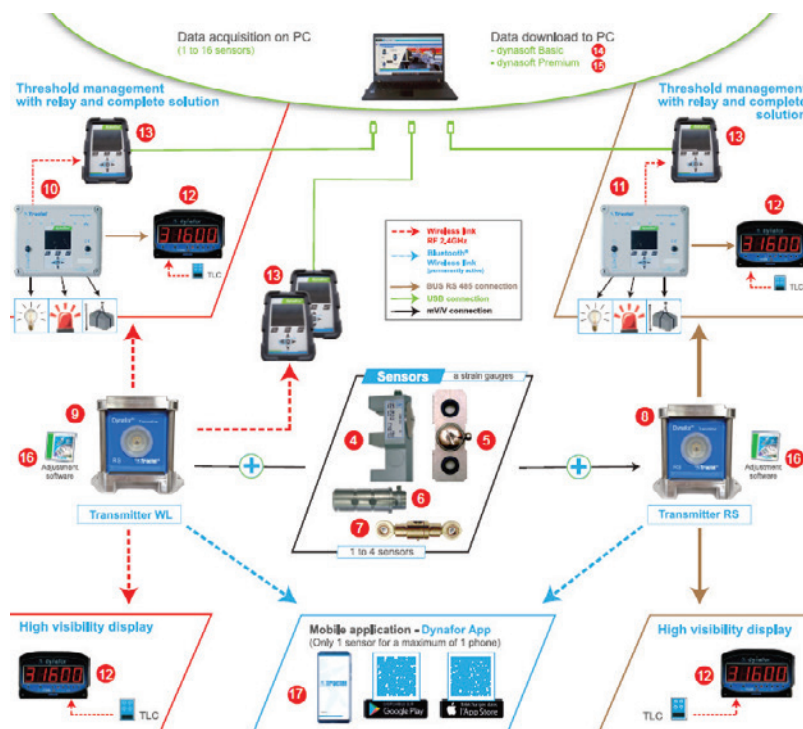

Dynasafe

1. Strain gauge sensor

Dynasafe HF35

Wire rope electronic sensor

- Electronic loadcell for installation on a wire rope
- 1% accuracy of measuring range
- Capacity range from 2t to 20t
- Compatible with wire rope diameters 5 to 45 mm
- Cable gland output
- Customized signal output : mV/V, 0-10V, 4-20mA, Hz

Specify wire rope diameter, capacity on fall and signal output with your request.



Dynasafe HF10

Wired loadlink

- Electronic loadcell for installation on dead-end or integrated in a machine
- 0.2% accuracy of measuring range
- Capacity range from 1.6t to 16t
- Cable gland output
- Customized signal output : mV/V, 0-10V, 4-20mA, Hz

Specify effort and signal output with your request.



Dynasafe HF50

Load pin

- Shear stress electronic loadcell for installation as a shaft
- Most integrated product with no headroom loss
- 0.5% accuracy of measuring range
- Mechanical design according to customer's specification
- Custom capacity
- Cable gland output
- Customized signal output : mV/V, 0-10V, 4-20mA, Hz

Fulfill the loadpin specification sheet with your request.



Others designs available. For any request please contact us at : sales.uk@tractel.com

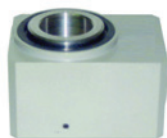

Signal conditioner

2. Connection



Dynafor Transmitter WL & RS

Conditionner



The Dynafor Transmitter WL & RS are conditionners used to format the signal generated by a strain gauge sensor into a signal readable by our wired and wireless accessories.

It can be used with any sensor that has a mV/V output.

- Capacity defined by the associated sensor
- WL version :
 - Radio-Frequency 2.4GHz chipset for wireless range up to 400m with our accessories (HHD, AL63, DMU and softwares)
 - Bluetooth chipset for a connection to any smartdevice equipped with our free app', up to 30m
 - Both Bluetooth and Radio-Frequency 2.4 GHz available
- RS version :
 - RS485 output (proprietary) for a wired connection with accessories.
 - Bluetooth chipset aswell as WL version
 - Both RS485 and Bluetooth available
- Powered by 3 AA batteries for WL version, RS485 for RS version
- Combined with our required software "Dynasoft Adjustment", the system {Dynafor Transmitter RS or WL + sensor} is adjustable by the end-user for high accuracy.

Model	Product Code
Dynafor Transmitter RS	293469
Dynafor Transmitter WL	293459

The delivery includes the Dynafor Transmitter WL & RS, its user manual, its rugged plastic cover and its declaration of conformity. Supplied in sturdy cardboard packaging

Dynasoft Adjustment

Option required to calibrate the system

The Dynasoft Adjustment is mandatory to calibrate the loadcell and its Transmitter. It allows the user to set the system capacity, and makes possible to reach high accuracy.

Model Name	Product Code
Dynasoft Adjustment	199529

Software is delivered with a USB dongle, used for the connection between the Transmitter and the PC.

Once the Transmitter is selected, the system can communicate with our wired and wireless Tractel accessories (DMU, HHD, AL), presented on next pages

Dynafor HHD

Wireless display



The Dynafor HHD is a complete and versatile handheld display.

Universal, it can be connected to our Dynafor Pro, Dynafor Expert and Dynafor Transmitter WL.

- Wireless range up to 400m
- Single and multi-sensors (max. 4) reading with sum function
- Multiple display units (daN, kg, t, US Ton, lbs,kN)
- Tare & Peak hold functions
- Ergonomic interface
- Settable alarms with incorporated buzzer
- Manual data recording with up to 100 measures
- Autonomy up to 24h. Equipped with rechargeable battery. Charger included.
- Can be used in combination with large displays AL63 and DMU for modular solutions
- Can be used with Tractel App at the same time
- QR Code apposed on product for technical and traceability documentation



Model	Product Code
Dynafor HHD	293449

The delivery includes the Dynafor HHD, its user manual, its rugged plastic cover and its declaration of conformity..
Supplied in sturdy cardboard packaging

Dynafor AL63

High visibility displays



The Dynafor AL63 is designed to visualize the efforts or loads measured by one up to 4 sensors in a large display.

It can be wirelessly connected to our Dynafor Pro, Dynafor Expert and Dynafor Transmitter WL, up to 200m range.

It also can be wired-connected to our Dynafor Transmitter RS.

- Connection from 1 up to 4 sensors, with automatic sum function.
 - Visibility up to 45 m
 - Tare, peak hold, unit's selection with the TLC remote control.
 - Communication between Dynafor AL63 and sensors either through BUS RS 485, either through RadioFrequency 2.4 GHz
 - Can be used with monitor Dynafor DMU
- Multiple configurations of monitors, sensors and displays are possible.



Model	Product Code
AL63 kit (incl. TLC remote control, connection unit)	294579
Power supply 110/230VAC -> 24 VDC	199046
Bus cable RS485 (per meter)	31411
Connection Unit	244019
Dynafor TLC remote control	293499

The delivery includes the Dynafor AL63, its user manual, a remote control TLC, and its declaration of conformity.
Supplied in sturdy cardboard packaging



Dynafor DMU

Display Monitoring Unit

The Dynafor DMU is a configurable safety device for managing 5 relays which are triggered in response to signals received from 1 or more electronic loadcells.

- Measure the rope tension or loads from 1 or more Dynafor Pro, Expert and Transmitter
- Manage 5 relays with adjustable thresholds and hysteresis
- Used for shutting down off equipments, powering on visual and audible alarms..
- Monitor the network
- Connect the unit to a AL63 LED display with a cable
- Connect the unit to a remote display HHD

Model	Product Code
Dynafor DMU - Display Monitoring Unit	293479
Power supply 110/230VAC -> 24 VDC	199046
Bus cable RS485 (per meter)	31411
Connection Unit	244019

The delivery includes the Dynafor DMU, its user manual, its declaration of conformity. Supplied in sturdy cardboard packaging



Dynasoft - software for Dynafor

Connect your Dynafor load cells to your PC for additional functionality

The Dynasoft suite is composed of several modules:

- **Dynasoft Download** allows the transfer of measurements stored in our Dynafor HHD to the PC
- **Dynasoft Threshold Management** allows to transfer the alarm data saved in our Dynafor HHD to the PC
- **Dynasoft Monitoring** to perform real-time monitoring, recording and processing. The software needs to be used conjointly with our Dynafor HHD, and one to 16 Dynafor loadcells.

Two packages are available. The basic and premium licenses are valid for an initial period of 1 year, which can be extended on expiration.

Model	Product Code
Dynasoft Basic (incl. Download & Threshold management) - First year	293509
Dynasoft Basic - renewal 1 year	287717
Dynasoft Premium (incl. Monitoring, Download & Threshold Management) - First year	294479
Dynasoft Premium - Renewal 1 year	287707

Softwares are delivered informatically, with an activation code. Software activation required Internet connection.



Dynarope

Tension meters HF37 and HF45

Dynarope HF37

Compact, lightweight and handy device for low capacities

The Dynarope tension meter HF37 is a precision device for measuring forces in a tensioned cable or rope, without dismantling the installation.

Can be used for guy wire maintenance, architectural wire rope installations, sailing ships, etc.

- Quick direct mounting on the wire or rope
- Capacity range from 50 to 3000 kg
- Extensive wire rope database
- 3% accuracy of measuring range, if wire rope and diameter included in the database
- Compatible with diameters from 5 to 16 mm
- LCD display directly on the sensor
- Possibility to add a wire or rope in the database

Model	W.L.L (kg)	Rope Diameter (mm)	Product Code
Kit Dynarope HF37/1/LPT	50 - 1 500	5 - 13	190008
Kit Dynarope HF37/2/LPT	100 - 3 000	5 - 16	190018

The delivery includes the Dynarope HF37, its display, the software Loader Light, its CE certificate and its manual. Supplied in a robust plastic case.



Dynaline HF 45

Adapted for lifeline

Specific model, based on HF37 technology, adapted to measure precisely tension in lifelines.

- Quick direct mounting on the wire or rope thanks to modified fixing hooks
- Capacity range from 50 to 600 kg
- Specific lifeline wire rope database
- 3% accuracy of measuring range, if wire rope and diameter included in the database
- Compatible with diameters from 8 to 12 mm
- LCD display directly on the sensor
- Possibility to add a wire or rope in the database

Model	W.L.L (kg)	Rope Diameter (mm)	Product Code
Kit Dynaline HF45/1/LPT	50 - 600	8 - 12	187998

The delivery includes the Dynaline HF45, its display, the software Loader Light, its CE certificate and its manual. Supplied in a robust plastic case.



Database extension and softwares

Model Name	Product Code
Option - Specific calibration for database	111347
Software Loader Tech - Update of database remotely	193018
Software Loader Full (incl. Loader Tech + Loader Light)	187978

In order to perform calibration, a specific sample is required.
Loader Light (unload data saved in the tensiometer) always included with the kit



Dynarope HF 36

Tension meter for high capacities

The Dynarope tension meter HF36 is a precision device for measuring forces in a tensioned cable or rope, without dismantling the installation. Can be used for equalising wire rope installations, guy wire tower applications, guy wire antennas and masts applications...

- Direct mounting on wire or rope, tightening by turning the wheel
- Extensive capacity range from 100 kg to 40t
- Various wire rope database
- 1% accuracy of measuring range, if wire rope and diameter included in the database
- Compatible with diameters from 5 to 44 mm
- Separate LCD display connected with LEMO cable
- Possibility to add a wire or rope in the database

Model Name	W.L.L (kg)	Rope Diameter (mm)	Product Code
Kit Dynarope HF36/1/LPT	100 - 5 000	5 - 13	187938
Kit Dynarope HF36/2/LPT	100 - 20 000	9 - 28	187948
Kit Dynarope HF36/3/LPT*	200 - 40,000	20 - 44	187958

*For efforts above 20t, the complementary hydraulic kit is required. Contact Tractel.

The delivery includes the Dynarope HF36, its displays, the LEMO cable connection, the software Loader Light, its CE certificate and its manual. Supplied in a robust plastic case.

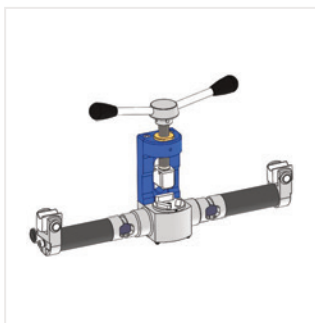

Dynarope HF 36/RWT

Tension meter designed for railway applications

The Dynarope tension meter HF36 model RWT is a very specific tensiometer designed to measure tension on catenaries, without dismantling the installation.

- Direct mounting on wire or rope, tightening by turning the wheel
- Modified support points to match catenaries shape
- Capacity range from 100 to 5000 kg with specific database
- 1% accuracy of measuring range, if wire rope and diameter included in the database
- Compatible with diameters from 9 to 28 mm
- Separate LCD display connected with LEMO cable

Model Name	W.L.L (kg)	Rope Diameter (mm)	Product Code
Kit Dynarope HF36/1/RWT	100 - 5 000	9 - 28	190688

The delivery includes the Dynarope HF36, its displays, the LEMO cable connection, the software Loader Light, its CE certificate and its manual. Supplied in a robust plastic case.

Database extension and softwares

Model Name	Product Code
Option - Specific calibration for database	122350
Software Loader Tech - Update of database remotely	193018
Software Loader Full (incl. Loader Tech + Loader Light)	187978

In order to perform calibration, a specific sample is required. Loader Light (unload data saved in the tensiometer) always included with the kit

Anchor test equipment

Anchor point testers and Dynaplug

Anchor Tester TA

Anchor testers TA are test specimens endowed with a breaking section calibrated to break under a determined traction force. The anchor tester must be installed between the anchor point to be tested and the loading device by means of shackles or any other adequate mechanical connection.

- Quick and reliable test
- Unique usage
- Capacity range from 600 to 4000 daN
- Breaking tolerance $\pm 10\%$

Model	Breaking load (daN)	Product Code
TA 600 - 20 plates	600	193269
TA 1000 - 20 plates	1 000	261769
TA 1200 - 20 plates	1 200	261779
TA 1500 - 20 plates	1 500	193279
TA 2000 - 20 plates	2 000	193289
TA 4000 - 10 plates	4 000	193299

The delivery includes the shear stress plates in batch of N plates, and its manual. Supplied in PE bag.



Dynaplug HF 44

Electronic anchor tester

The Dynaplug anchor tester is an electronic load cell designed to measure anchor strength in construction material. Its shape as a tripod has been especially designed to minimize its influence on the concrete around the fixing.

- Stand-alone anchor tester
- Capacity range from 1 500 to 5000 daN
- 0.5% accuracy of measuring range
- Height of legs adjustable between 70 and 190 mm
- Multiple accessories provided with the tester
- LCD display integrated on the device
- Data saving and possibility to monitor the tension on a PC in option

Model	W.L.L (daN)	Product Code
Kit Dynaplug HF44/1/LPT	1500	190028
Kit Dynaplug HF44/2/LPT	2500	190038
Kit Dynaplug HF44/3/LPT	5000	190048

The delivery includes the Dynaplug HF44, 4 studs M10/M12/M14/M16 and one traction fork, 3 threaded rods to adjust the height of the legs, the software Loader Light, its CE certificate and its manual. Supplied in a robust plastic case.



 Order products on day 1, will be shipped no later than day 2.

 Order products on day 1, will be shipped no later than day 6. Maximum quantities apply for this service.

 Available on request. Please enquire about delivery times of these items.