

### Applications

The NX is designed for lifting and revolving without marring of smooth or polished pieces such as stainless steel plates, aluminium, pre-lacquered plates, wood, laminated sheets, marble, concrete, glass, plastic and many other fragile surfaces.

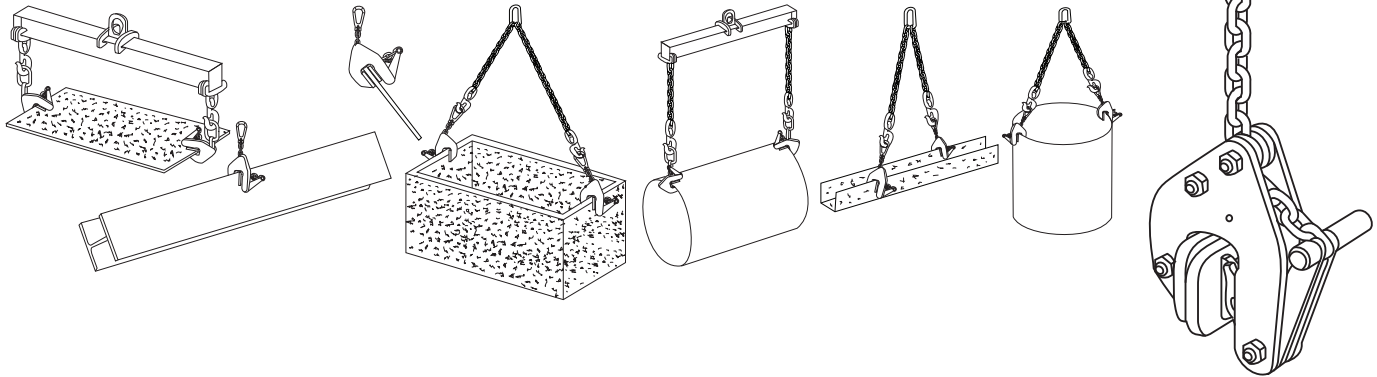

### Description

Clamps fitted with jaws coated with polyurethane enabling to lift and revolve loads without marring their surface. These products are equipped with a safety spring mechanism and an automatic grasping which respectively permits a permanent contact of the cam onto the piece to be lifted, even when it is being put down and causes the clamp's closing when the plate is correctly positioned ie at the back of the clamp's throat. The chain enables the turning and makes the clamp's positioning easier.

### Functioning

To open the clamp's jaws, push the handle downwards until the trigger activates ; the handle remains in a down position. When the load is driven home at the back of the clamp's throat, the trigger activates and the clamp locks itself automatically. Lifting causes proportional clamping, thus avoiding material damage risk.

To release the clamp, push down the handle completely; the clamp is thus locked in the open position. Loads may be grasped horizontally or vertically and revolved in inverse position (90° or 180°).

Adjustable model: adjust the clamp's opening before use. The adjusting increment is 20 mm.(7/8 inch).

*Fragile pieces:* use the manual opening and locking thanks to the handle without bringing it to its limit stop (trigger not activated).

### Important instructions

- This clamp can also be used for usual steels.
- The plate or piece to be lifted must always be driven home into the throat of the clamp.
- No limit regarding surface hardness of loads to be lifted. Never use on greasy or oily pieces.
- Do not use the automatic grasping mechanism on fragile loads.
- To avoid injury, ensure the clamps are always unlocked when not in use (closed jaws).
- The minimum weight of lifting load should be equal to 5% of the clamp's WLL (eg if clamps WLL is 2,200 lbs. (1000 kg), then minimum weight is 110 lbs. (50 kg). This value is given for a clamp in good working order and respecting Tractel Inc. conditions of use and recommendations. Consult Tractel in case of loads with weight inferior to the minimum recommended value.
- Lifting clamps are not suitable for creating permanent joints.
- Never lift more than one plate at a time.
- Apply the downgradation if necessary.
- Working temperature: -20° to +80°C.(-4 to 176F)

- *Lifting function:* do not exceed the allowable 15° angle between the chain and the clamp's flanges.

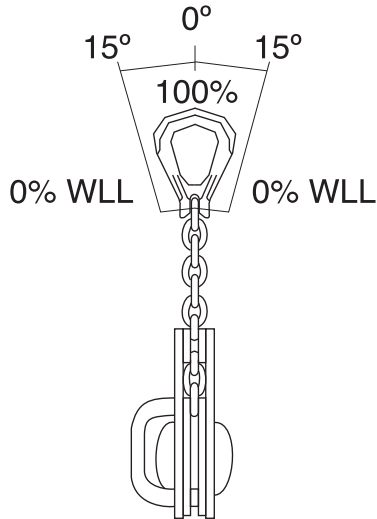

- *Turning function:* for this application, the clamp's working load limit is divided by 2.

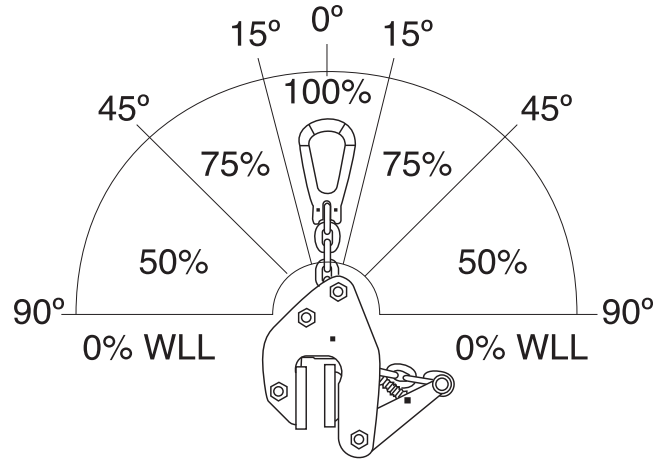

- *Function lifting of loads in a vertical position with 2 clamps and no lifting beam:* do not exceed the 30° sling angle.

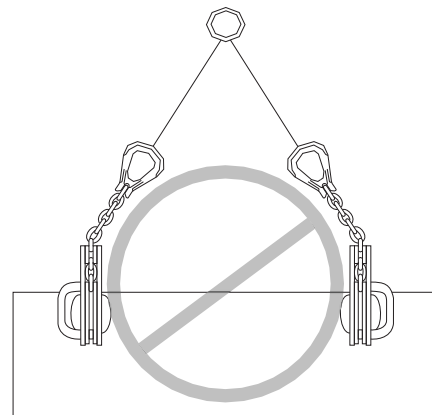
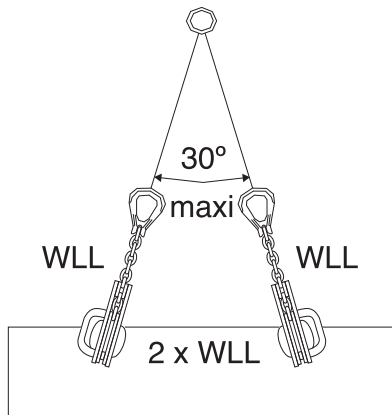

- *Function lifting of loads in a horizontal position using 2 clamps at least and a lifting beam:* the working load limit of each clamp is divided by 2.

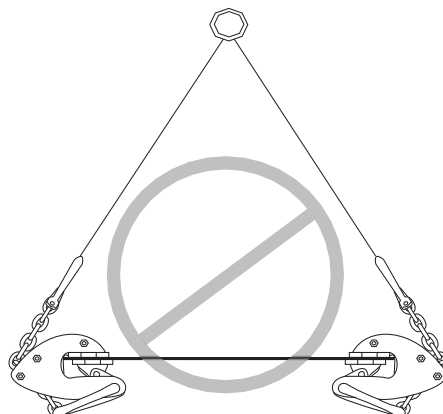
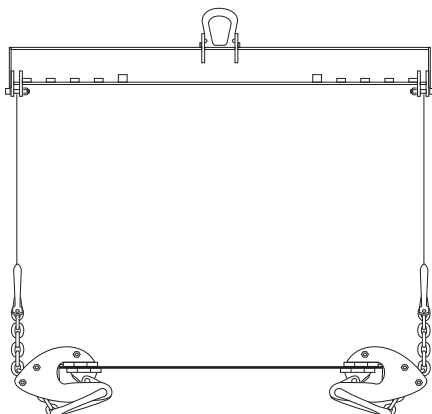

**General characteristics**

- Manufactured without load bearing welds.
- Hot epoxy coating.
- Safety factor: 3 in accordance with ANSI B30.20.
- Product delivered with instructions for use.
- Every clamp is tested twice the working load limit.
- 1 year warranty against any defect of fabrication.

**Dimensional characteristics**

Ref.	Item Number	WLL lbs. (t)	Opening		A		B	C	D	E	F		G	H	I	J	K	L	M	O	P	Chain Dia.	Weight
			min	max	min	max					min	max											
			kg.	In./mm	In./mm	In./mm					In./mm	In./mm											
NX05 0-20	50408	1100 (0.5)	0	13/16	6 3/4	8 11/16	8 3/16	3 1/4	1 15/16	4 1/8	14 13/16	18 1/8	1 5/8	2 13/16	1 5/8	1/2	7/16	3 1/8	2 3/4	X	5 23/32	3/4	9.9
		500	0	20	171	221	208	82	50	105	376	460	42	71	41	13	11	80	70	X	118	7	4.5
NXR05 0-100	50428	1100 (0.5)	0	3 15/16	7	12 1/8	8 3/16	3 1/4	2 5/16	4 1/8	14 15/16	18 3/8	2 5/16	2 13/16	1 5/8	1/2	7/16	3 1/8	2 3/4	13/16	5 23/32	3/4	13.2
		500	0	100	178	308	208	82	58	105	379	466	58	71	41	13	11	80	70	20	118	7	6
NXR05 20-120	50438	1100 (0.5)	13/16	4 1/4	8	12 7/8	8 3/16	3 1/4	2 5/16	4 1/8	14 15/16	17 9/16	2 5/16	2 13/16	1 5/8	1/2	7/16	3 1/8	2 3/4	13/16	5 23/32	3/4	12.8
		500	20	120	203	327	208	82	58	105	380	446	58	71	41	13	11	80	70	20	118	7	5.8
NXR05 40-140	50448	1100 (0.5)	1 9/16	5 1/2	8 3/4	13 11/16	8 3/16	3 1/4	2 5/16	4 1/8	15 1/16	18 1/16	2 5/16	2 13/16	1 5/8	1/2	7/16	3 1/8	2 3/4	13/16	5 23/32	3/4	13.2
		500	40	140	223	348	208	82	58	105	382	459	58	71	41	13	11	80	70	20	118	7	6
NX1.5 0-30	50418	3300 (1.5)	0	1 1/8	8 2/3	11 1/4	10 3/16	4 3/16	2 11/16	4 3/4	20	24	2 3/16	3 7/16	1 15/16	1/2	5/8	3 15/16	3 1/2	X	5 23/32	13/32	24
		1500	0	30	220	285	256	104	68	120	508	610	56	87	49	13	16	100	90	X	145	10	11

**NX**

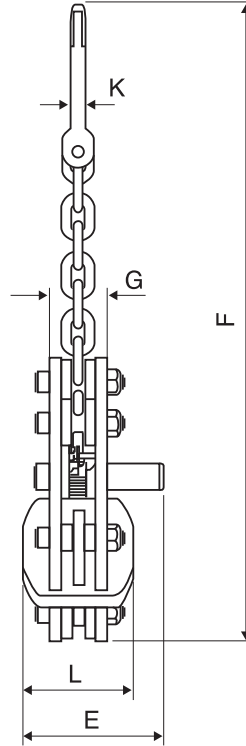
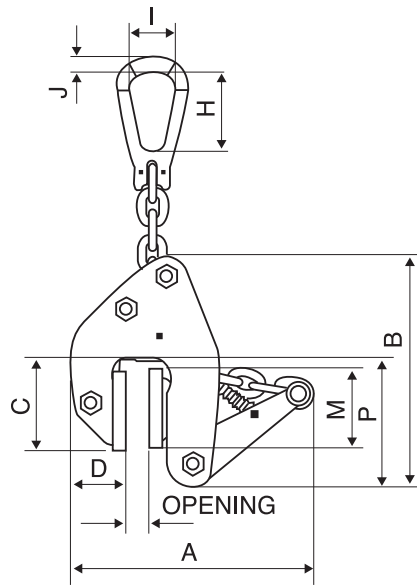

**NXR**

