

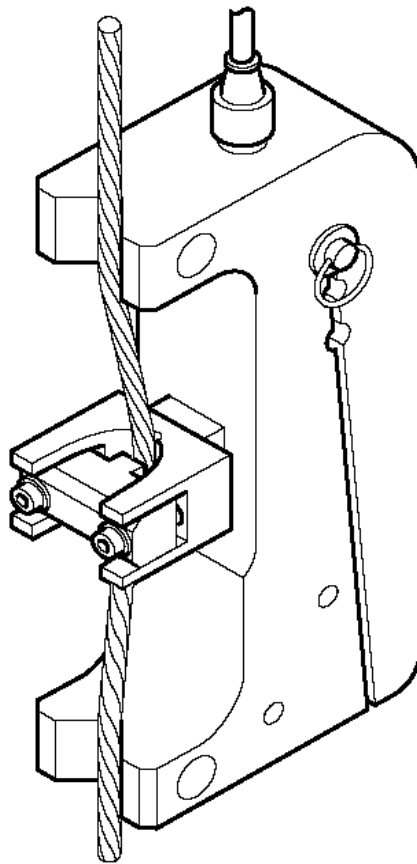

HF 32/3/B Universal load cell



**Operating
and
maintenance
manual**

GENERAL WARNING	2
INSTALLATION OF HF 32 LOAD CELL	3 – 4 - 5
INSTALLATION AND CONNECTION OF HF 85 MONITOR	6
OPERATION AND INSTALLATION OF HF 32 AND HF 85	7

GENERAL WARNING

- 1- Reading and fully understanding the technical data sheets relating to this equipment is essential for the best use of this high technological material that you have received . All the technical data sheets are available on request.**
- 2- Before installing and operating Dynasafe equipment it is essential for the safe and correct operation of the material that this manual be read and fully understood and that all the instructions be followed. This manual should be made available to every operator. Extra copies of this manual will be supplied on request.**
- 3- The installation and the operation Dynasafe equipment should only be carried out in accordance with the appropriate health and safety at work regulations.**
- 4- Never apply to the Dynasafe a load or an effort in excess of the working load limit, and never use it for an operation for which it is not intended.**
- 5- TRACTEL S.A.S declines any responsibility for the consequences of dismantling or altering the machine by any unauthorized person.**
- 6- Dynasafe equipment must not be used in explosive atmospheres.**
- 7- Dynasafe equipment must only be used in a system designed for lifting people after ensuring that the appropriate operating coefficients have be used in accordance with the current regulations.**
- 8- Prior to the use of Dynasafe equipment with complementary equipment relaying the signals to an operating system, the user or installer of this system should carry out a specific risk analysis of the operating functions. The appropriate measures should be taken to obviate risks identified.**

INSTALLATION OF HF 32/ /B LOAD CELL

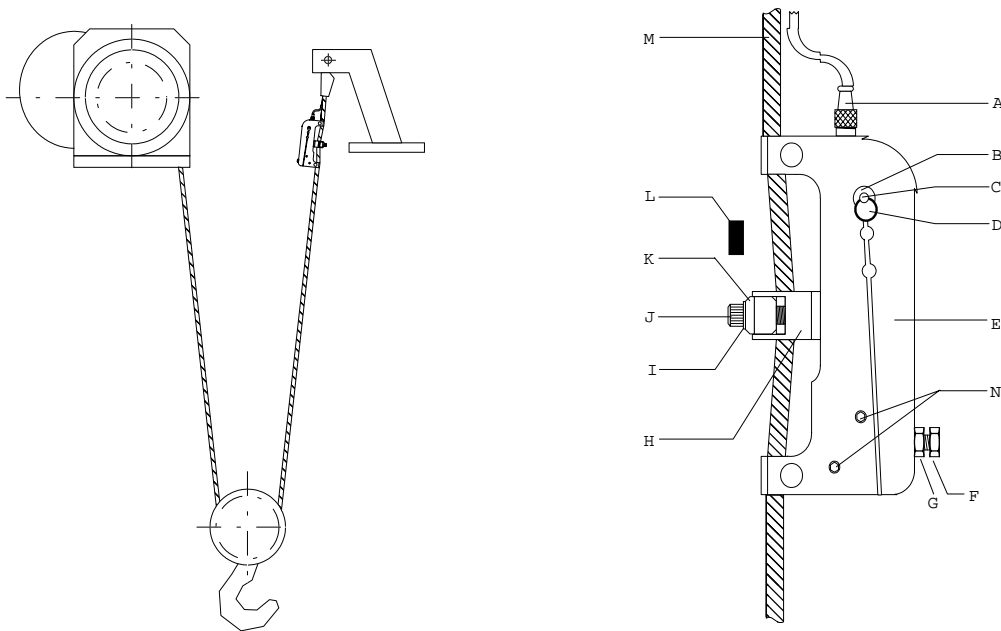

Fig. 1

Components of the load cell

A- 2 m connecting cable	F- Locking nut	K-Tightening.
B- Flat washer.	G- Tare screw.	L-Rubber compression pad.
C- Adjusting pin.	H-Traction part.	M-Wire rope.
D- Locking ring.	I- Safety washer.	N- Fixing screws for circuit breaker.(do not touch)
E- Load cell body.	J- Tightening screw.	

Procedure for installing load cell

Essential condition : the hook of the lifting system should be free of any load.

- Position the adjusting pin as a function of the load range and wire rope diameter (see p. 4).
- Remove the tightening bracket (K).
- Position the load cell on the wire rope near the dead end/fixed point. The connecting cable should be uppermost.
- Replace the tightening bracket (K) ensuring that it is correctly positioned depending on the diameter of the wire rope. (See page 4)
- Adjust the tightening screws (J) symmetrically (+/- 0.5 kgm) to ensure that there is no risk of moving the load cell out of line with the wire rope. Excessive tightening may break the bracket.
- Operate the lifting system up to the upper limit switch and ensure that the sheaving or bottom block does not foul the load cell. If this happens adjust the upper limit switch so that there is an appropriate distance between the load cell and the bottom block. Also check that when the bottom block is in the upper position the load cell is not in contact with the overhead crane.
- Wire the connecting cable from the load cell to the control box. Ensure that the cable is secured.

INSTALLATION OF HF 32/3/B LOAD CELL

Positioning the adjusting pin as a function of the effort in the wire rope

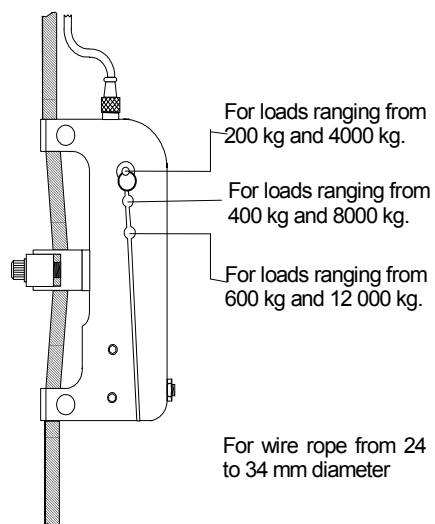

Pinçage du capteur sur le câble

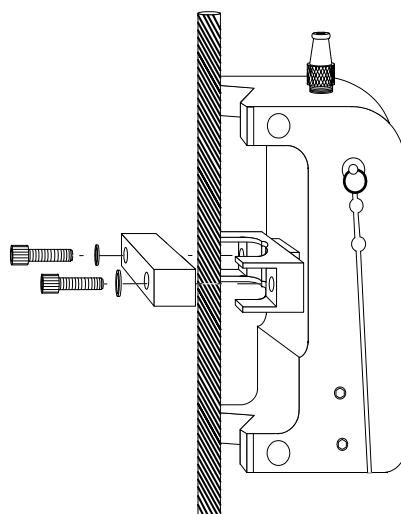

Fig. 2

Important remarks

- Before loading and if no preadjustment has been made in the factory, unscrew the adjustment screw at the most, because you risk to destroy the transducer.
- To select pin and bracket position, load has priority over wire rope diameter.
- Never remove the locking nut (G) because tare screw (F) could damage the microswitch.

OPERATION AND ADJUSTMENT OF HF 85 LOAD CELL

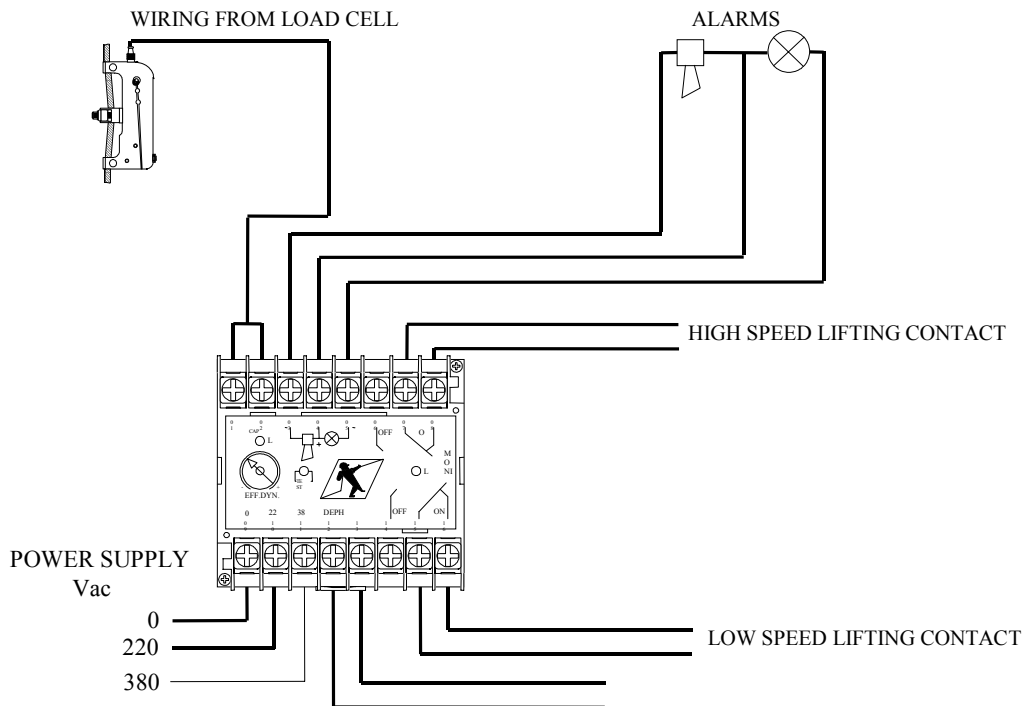

Fig. 3

The switch is 25 mA 24V AC or 2 mA 15 V DC. It is therefore necessary to check the interface compatibility if HF 85 is not used.

Procedure for installation and connection

- Mount the HF 85 monitor to the DIN rail in the electrical control box containing the lifting controls.
- Wire the high speed lifting contactor coil in series between terminals 07 and 08.
- Wire the high speed lifting contactor coil in series between terminals 15 and 16.
- Wire the electronic alarm, HF90/1, to terminals 03 and 04 taking care to observe the correct polarity. The alarm function is deactivated automatically 15 seconds after the detection of an overload condition.
- Wire the electronic flashing light, HF90/2, to terminals 04 and 05 taking care to observe the correct polarity. This flashing light function remains active whilst there is an overload condition.
- Connect the load cell wires to terminals 01 and 02 (non –polarized)
- Connect the power supply to the monitor : 220Vac to terminals 09 and 10 or 380 Vac to terminals 09 and 11.

Note: If necessary connect terminals 12 and 13 to normally open (NO) potential free contactor on the high and low speed lowering contactor to eliminate the possibility of detecting an overload condition and therefore the triggering of the alarms during lowering. In fact, the dynamic effects in the dead end wire rope are greater on lowering than on lifting.

INSTALLATION AND ADJUSTMENT OF HF 32 AND HF 85

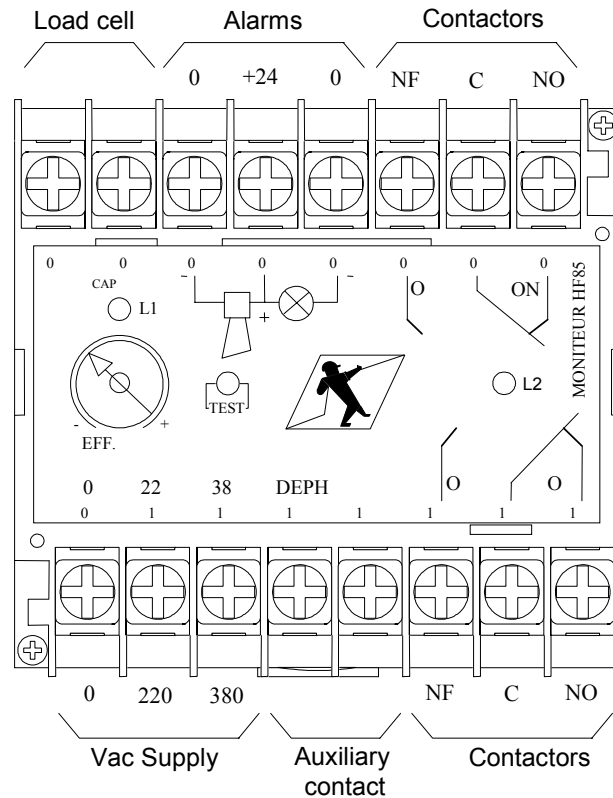

Fig. 4

Test function

Once the load cell has been fitted and the various connections have been made to the monitor, there is a test procedure to check the correct operation for the installation.

- Check that the hook of the lifting system is free of any load.
- Press the test button on the front of the monitor. (This button has the effect of simulating an overload condition).
- Once the test button has been pressed, the LED « L1 » should light up whilst the LED « L2 » will light up when the dynamic effect of the value of the trip point has been reached. (see page 8, point 7).
- Simultaneously, the relays trip and the alarms should operate.
- When the test button is released, it takes 5 seconds for the contactors of the monitor to reset themselves to the « ON » position.

OPERATION AND ADJUSTMENT HF 32 AND HF 85

Adjustment of the safety trip point

Essential conditions :

- The load cell must be correctly installed and wired.
- The hook of the lifting system should be free of any load.
- A successful operating test

Equipment required :

- A load ("Pm") equivalent to 100 % of the working load limit of the lifting system .
- An additional load equivalent to 10 % of « Pm ».

	ACTION	EXPLANATION
1	Lift the two loads (100% + 10% of Pm) by +/- 10 cm.	The additional 10 % load represents the overload value permitted under the European directives. If an overload situation is detected in the wire rope (without lifting the loads) the preadjustment of the load cell in the factory is too low for your lifting system. Solution: release the tare screw (F- see fig. 4) one turn at a time and restart at the beginning of point 1.
2	To adjust the safety trip point.	Use the tightening screw (F). <u>Warning : incorrect adjustment may damage the circuit – breaker.</u> Do not forget the locking nut (G). The switch is a normally closed contact (NC), requiring the opening of the switch to set off an overload condition. Turn clockwise to reduce the value of the trip point. Turn anticlockwise to increase the value of the trip point
3	Lower the loads	
4	Remove the additional load (10% of « Pm »)	
5	Lift load « Pm » using slow speed lifting	No overload condition should be detected. However, should the overload condition be tripped, see point 7 : Dynamic effects filter.
6	Lift load « Pm » using high speed lifting.	No overload condition should be detected. However, should the overload condition be tripped, see point 7 : Dynamic effects filter.
7	Dynamic effects filter using potentiometer « EFF. DYN »	Under certain conditions, the dynamic effects may create an overload condition which will set off the safety system. The potentiometer on the front of the monitor acts as a filter for this phenomenon by slowing down the reaction of the relays in relation to the opening of the microswitch. The potentiometer « EFF. DYN » has an adjustment range of 0 seconds (-) to ± 3 seconds (+).

NOTES :