

The FabEnCo FabRail's modular construction enables countless configurations. It is available in standard kits and customizable systems. Ships with fittings pre-assembled to uprights for easy installation. Remember to add your FabEnCo Safety Gate to complete your protection.

Kits

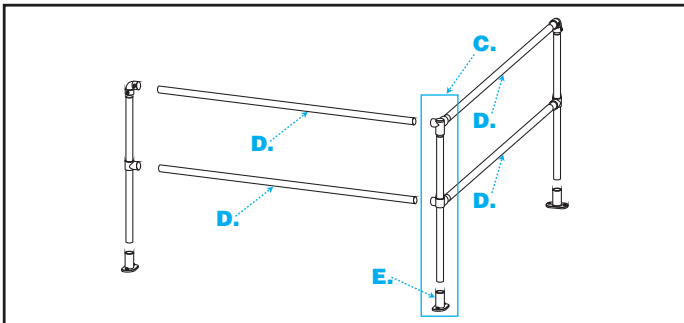
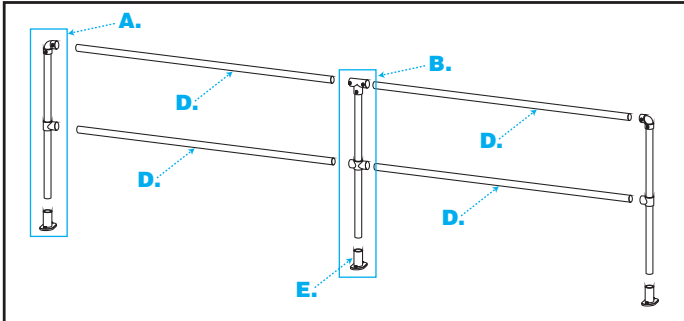

Hardware Parts

- A. End Upright (pre-assembly)
- B. Mid Upright (pre-assembly)
- C. Corner Upright (pre-assembly)
- D. 1.90 dia. 84" Horizontal Rail
- E. 1050.40 Base Flange

Installation

Step 1: Layout FabRail sections for required protection area using appropriate spacing.

Step 2: Mark hole locations for mounting using the 1050-40 Base Flange fitting as a template.

Step 3: Drill appropriate holes for type of fastener to be used. (Concrete Anchor, Lag Bolt, Hex Head Cap Screw, etc.)

*(The 1050-40 Base Flange has 9/16" diameter holes to accept 1/2" diameter Anchors or Fasteners.) * Fasteners NOT supplied by FabEnCo.*

Step 4: Repeat above steps for each section of rail.

Step 5: Using 5/16" Hex Socket tighten all set screws on fittings to 29 lb-ft.

** For custom applications please consult manufacturer.*

Systems

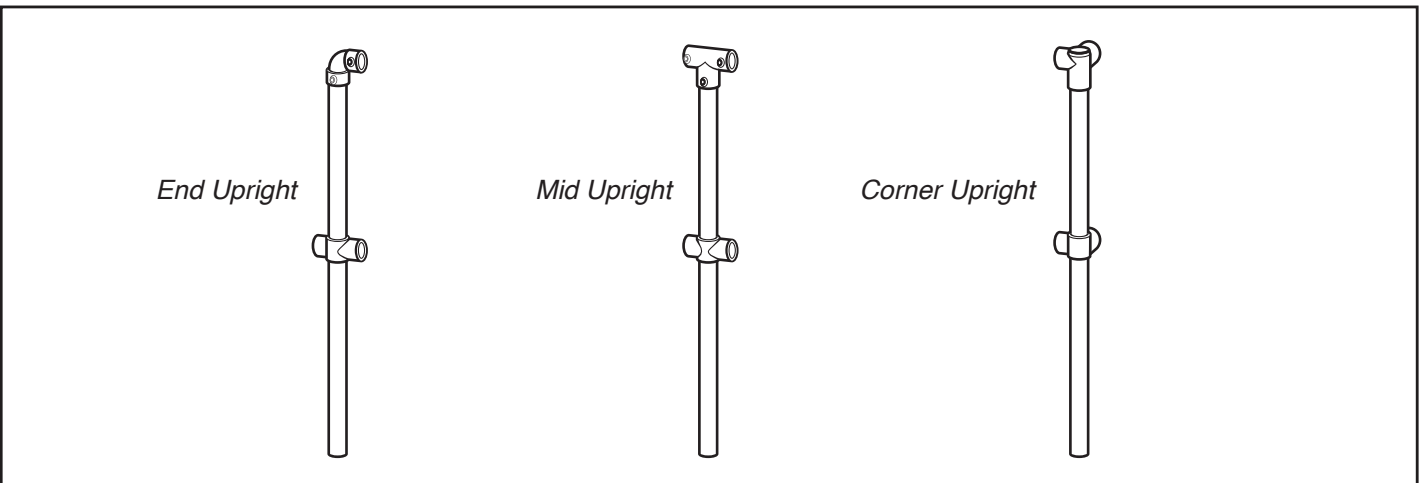

For additional information or assistance, call 1-800-962-6111 or e-mail us at info@safetygate.com

For additional information, please visit our website at www.safetygate.com